

# LIQUID CRYSTAL DISPLAY MODULE

## Product Specification

<b>PRODUCT NUMBER</b>	<b>LMR5413</b>
-----------------------	----------------

INTERNAL APPROVALS		
Product Manager	Engineering	Document Control

Product No.	LMR5413	REV. H
-------------	---------	--------

Page	1 / 32
------	--------

## TABLE OF CONTENTS

<b>1</b>	<b>PRODUCT SPECIFICATION .....</b>	<b>4</b>
1.1	<i>GENERAL SPECIFICATIONS .....</i>	<i>4</i>
1.2	<i>AVAILABLE FLUID AND POLARIZER TYPES .....</i>	<i>5</i>
1.3	<i>AVAILABLE BACKLIGHT TYPES AND COLORS .....</i>	<i>5</i>
1.4	<i>CHOICE OF BACKLIGHT COLORS AND LCD SURFACE LUMINOSITIES .....</i>	<i>5</i>
<b>2</b>	<b>MECHANICAL DRAWING .....</b>	<b>6</b>
2.1	<i>FOR ALL BACKLIGHT TYPES EXCEPT SUNBURST YELLOW AND RGB .....</i>	<i>6</i>
2.2	<i>FOR RGB BACKLIGHT TYPE .....</i>	<i>7</i>
2.3	<i>FOR SUNBURST YELLOW BACKLIGHT TYPE .....</i>	<i>8</i>
<b>3</b>	<b>PIN CONNECTIONS .....</b>	<b>9</b>
<b>4</b>	<b>THE STEP-UP VOLTAGE CIRCUITS.....</b>	<b>10</b>
<b>5</b>	<b>LCD GLASS LAYOUT .....</b>	<b>11</b>
<b>6</b>	<b>RECOMMENDED CIRCUIT SCHEMATIC.....</b>	<b>12</b>
<b>7</b>	<b>ELECTRO-OPTICAL CHARACTERISTICS .....</b>	<b>13</b>
<b>8</b>	<b>THE LED BACKLIGHT .....</b>	<b>14</b>
8.1	<i>MECHANICAL DRAWING FOR RGB BACKLIGHT .....</i>	<i>14</i>
8.2	<i>MECHANICAL DRAWING FOR ALL BACKLIGHT TYPE EXCEPT RGB.....</i>	<i>15</i>
8.3	<i>BACKLIGHT ELECTRO-OPTICAL CHARACTERISTICS .....</i>	<i>16</i>
<b>9</b>	<b>RELIABILITY TEST .....</b>	<b>19</b>
<b>10</b>	<b>THE LCD MEASURING METHOD AND EQUIPMENT .....</b>	<b>20</b>
<b>11</b>	<b>INITIALIZING AND PROGRAMMING.....</b>	<b>23</b>
<b>12</b>	<b>PART NUMBER DESCRIPTION FOR AVAILABLE OPTIONS .....</b>	<b>30</b>
<b>13</b>	<b>STANDARD SPECIFICATIONS FOR PRODUCT QUALITY .....</b>	<b>31</b>
<b>14</b>	<b>HANDLING PRECAUTIONS .....</b>	<b>32</b>

**REVISION RECORD**

<b>Rev.</b>	<b>Date</b>	<b>Page</b>	<b>Par.</b>	<b>Comment</b>	<b>ECN no.</b>
A	11/21/08	--	--	New DCA Specification – Combined all LMR5413 versions.	E3926
B	6/26/09	10	--	LCD Glass layout added	E4116
C	8/14/09	8	--	PIN definition updated	E4162
D	10/23/09	12	--	Added LCD current consumption	E4200
E	12/2/10	5	--	RGB Backlight added	E4389
F	7/11/13	12,27,28	--	Updated recommended circuit. Added read EEPROM procedure.	E4826
G	8/29/13	13,17,18	--	LCD operating voltage updated. RGB B/L spec updated.	E4847
H	11/05/13	12	--	Updated recommended circuit schematics.	4880

# 1 PRODUCT SPECIFICATION

## 1.1 GENERAL SPECIFICATIONS

ITEM	CONTENTS	UNIT
Outline Dimension* <sup>1</sup>	85.0 (W) x 55.0 (H) x 6.50 (D)	mm
Active Area	64.78 (W) x 34.54 (H)	mm
Viewing Area	78.60 (W) x 39.60 (H)	mm
Dot Size	0.25 (W) x 0.25 (H)	mm
Display Format	240 x 128	Dots
Viewing Direction	6:00	O'clock
Duty Ratio	1/128	Duty
Bias Drive	1/12	Bias
Module Operating Voltage	3.0	Volts
LCD Operating Voltage	11.6	Volts
IC Controller	ST7529	--
Operating Temperature	-20 ~ 80	°C
Storage Temperature	-30 ~ 80	°C
RoHS Compliant	Yes	-

\*Note 1: The outline dimensions for Sunburst Yellow backlight type will be 85.0 (W) x 55.0 (H) x 7.00 Max (D) mm due to the addition of Yellow filter.

## 1.2 AVAILABLE FLUID AND POLARIZER TYPES

LCD TYPE		STN		FSTN	
		Normal Temp.	Wide Temp.	Normal Temp.	Wide Temp.
Transmissive	Negative	N/A	✓	N/A	✓
Transflective	Positive	N/A	N/A	N/A	✓

## 1.3 AVAILABLE BACKLIGHT TYPES AND COLORS

BACKLIGHT COLOR	Jade Green	Arctic White	Warm Amber	Midnight Blue	Tangerine Orange	Sunburst Yellow	RGB Type
Edge LED	✓	✓	N/A	✓	✓	✓	✓

## 1.4 CHOICE OF BACKLIGHT COLORS AND LCD SURFACE LUMINOSITIES

-	MIDNIGHT BLUE	JADE GREEN	TANGERINE ORANGE	SUNBURST YELLOW	RGB TYPE	ARCTIC WHITE	UNIT
FSTN /Transmissive/Negative	10.7	6.5	4.5	32.0	6.0 (R), 10.0 (G) & 4.0 (B)	47.0	Cd/m <sup>2</sup>
FSTN /Transflective/Positive	N/A	N/A	N/A	N/A	5.0 (R), 9.0 (G) & 3.0 (B)	71.0	Cd/m <sup>2</sup>
STN /Transmissive/Negative	N/A	N/A	N/A	N/A	N/A	42.0	Cd/m <sup>2</sup>

## 2 MECHANICAL DRAWING

### 2.1 FOR ALL BACKLIGHT TYPES EXCEPT SUNBURST YELLOW AND RGB

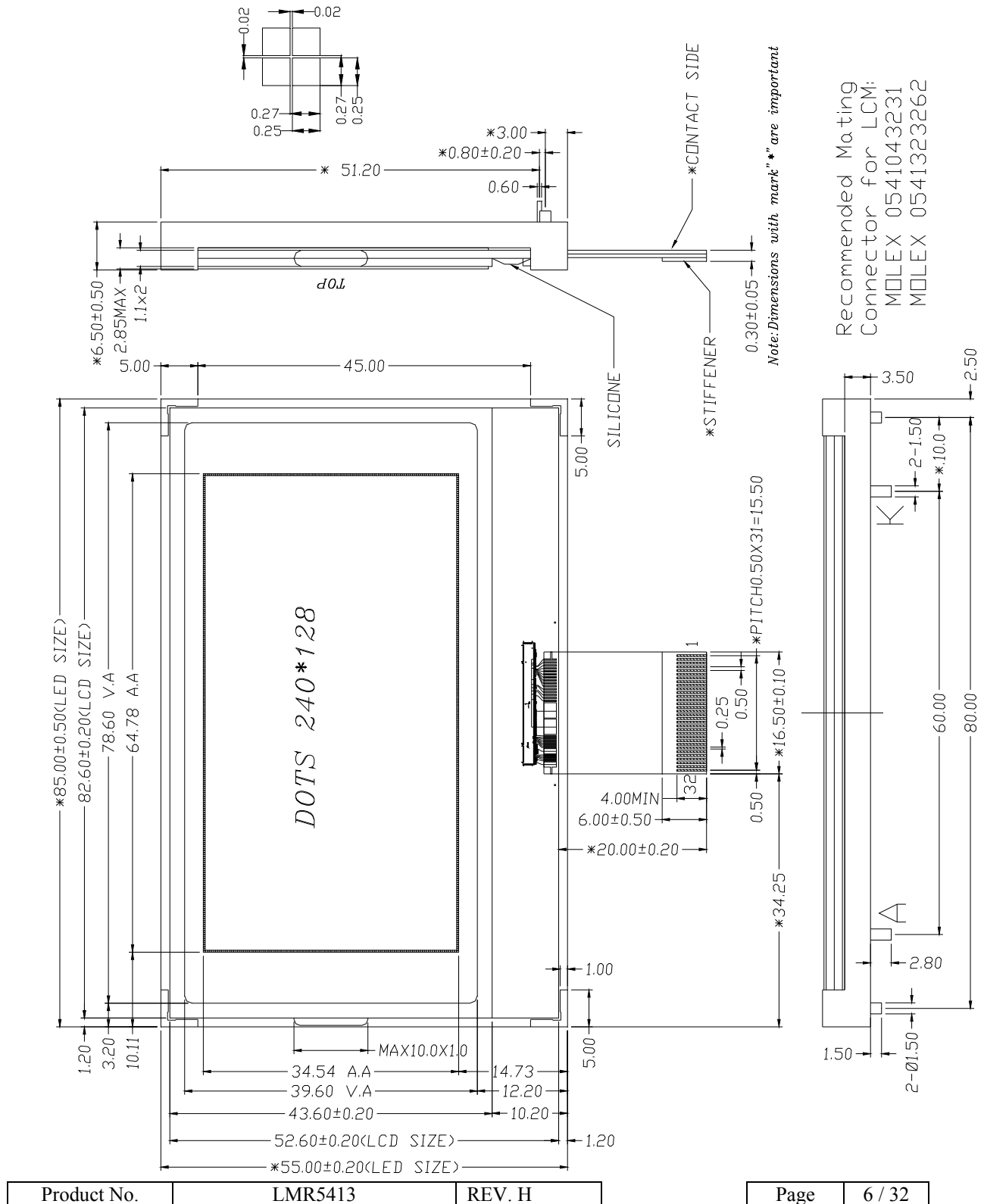

## 2.2 FOR RGB BACKLIGHT TYPE

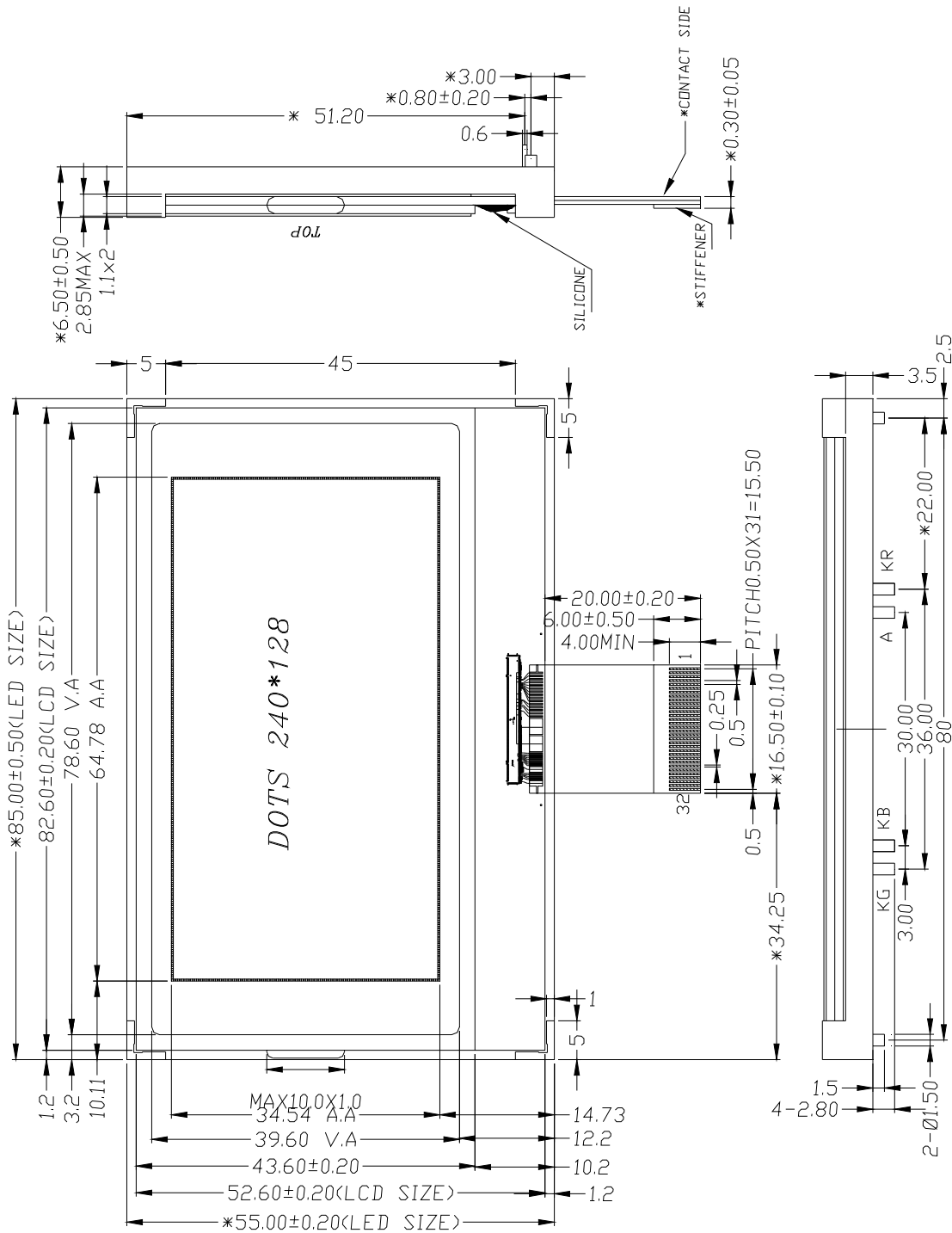

Product No.	LMR5413	REV. H
-------------	---------	--------

Page	7 / 32
------	--------

2.3 FOR SUNBURST YELLOW BACKLIGHT TYPE

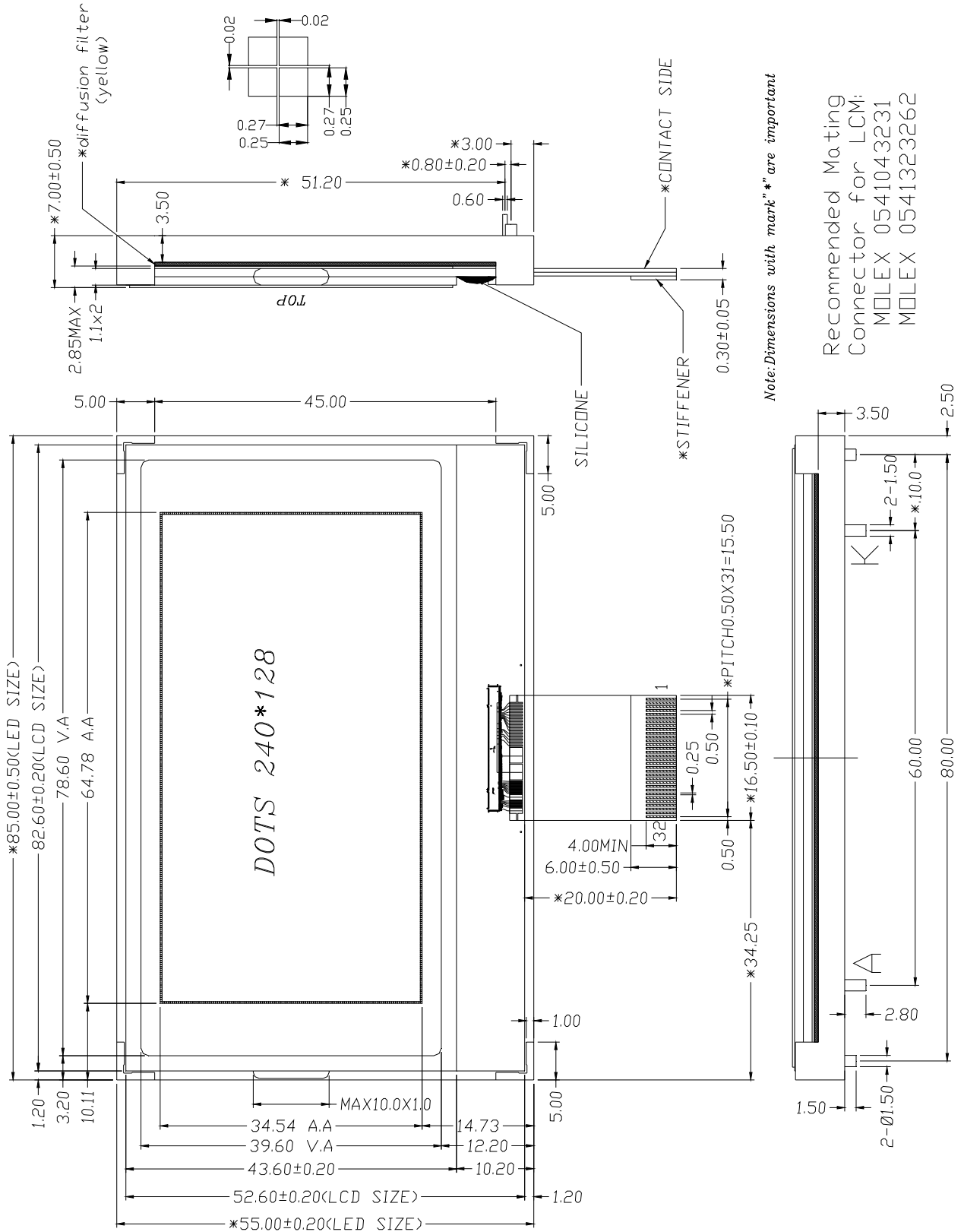

Product No.	LMR5413	REV. H
-------------	---------	--------

Page	8 / 32
------	--------



### 3 PIN CONNECTIONS

Pin No.	Symbol	Function
1	A0	Identify The Data or a Command.
2	RW-/WR	Read/Write execution control
3~10	D0-D7	The 8-bit bi-directional data bus to be connected to the MCU in parallel interface mode
11	E-/RD	Read/Write execution control
12	RST	Reset input pin
13	IF1	Parallel/Serial data input select input : High = 80 series 8-bit parallel Low= 68 series 8-bit parallel
14	IF3	Parallel/Serial data input select input: Low= 80 series 8-bit parallel High= 68 series 8-bit parallel
15	XCS	Chip select input pin
16	VSS	Ground
17	VDD	Chip's power supply pin
18	C7P	Connection Pin for Voltage Converter
19	C5P	Connection Pin for Voltage Converter
20	C3P	Connection Pin for Voltage Converter
21	C1N	Connection Pin for Voltage Converter
22	C1P	Connection Pin for Voltage Converter
23	C2P	Connection Pin for Voltage Converter
24	C2N	Connection Pin for Voltage Converter
25	C4P	Connection Pin for Voltage Converter
26	C6P	Connection Pin for Voltage Converter
27	VLCD	If the internal voltage generator is used, the $V_{LCDIN}$ & $V_{LCDOUT}$ must be connected together.
28-32	V4, V3, V2, V1, V0	LCD driving supply voltage. Connect to ground when internal power circuit is active, *refer to recommended schematic.

Note: IF2 is internally hardwired to "High"

## 4 THE STEP-UP VOLTAGE CIRCUITS

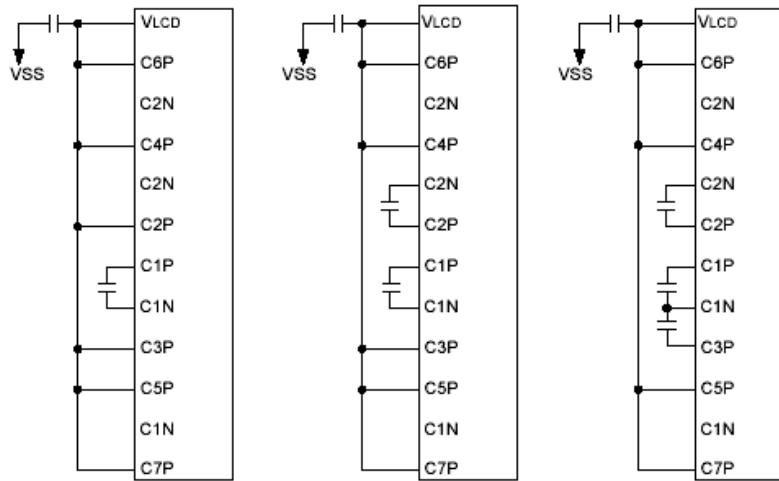

2x step-up voltage circuit

$$V_{LCD} = 2 \times V_{DD2} = 6V$$

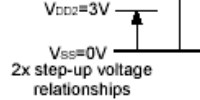

2x step-up voltage relationships

3x step-up voltage circuit

$$V_{LCD} = 3 \times V_{DD2} = 9V$$

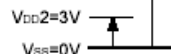

3x step-up voltage relationships

4x step-up voltage circuit

$$V_{LCD} = 4 \times V_{DD2} = 12V$$

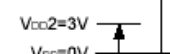

4x step-up voltage relationships

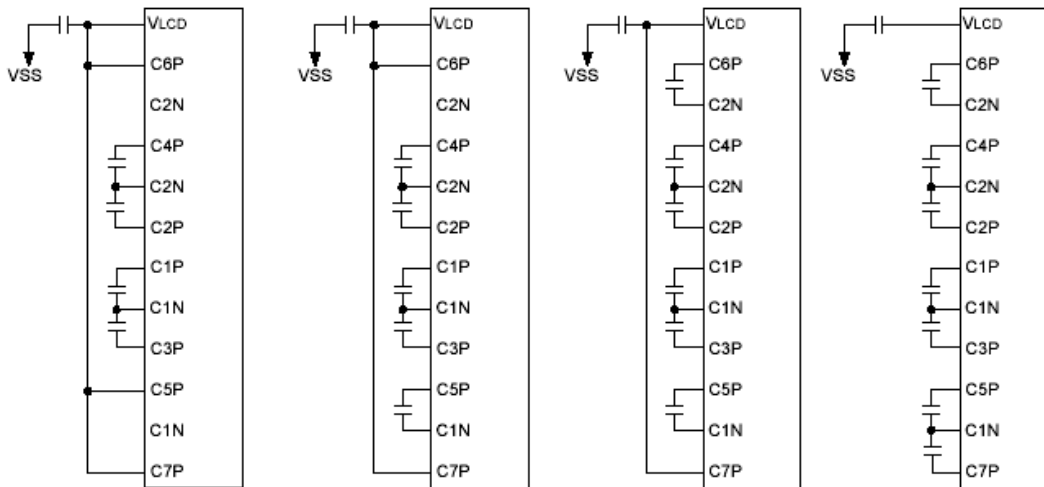

5x step-up voltage circuit

$$V_{LCD} = 5 \times V_{DD2} = 15V$$

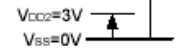

5x step-up voltage relationships

6x step-up voltage circuit

$$V_{LCD} = 6 \times V_{DD2} = 18V$$

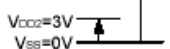

6x step-up voltage relationships

7x step-up voltage circuit

$$V_{LCD} = 7 \times V_{DD2} = 16.8V$$

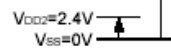

7x step-up voltage relationships

8x step-up voltage circuit

$$V_{LCD} = 8 \times V_{DD2} = 19.2V$$

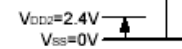

8x step-up voltage relationships

**Note: The regulating capacitance on V0 ~ V4 should be between 1.0 to 2.2  $\mu$ F.**

5 LCD GLASS LAYOUT

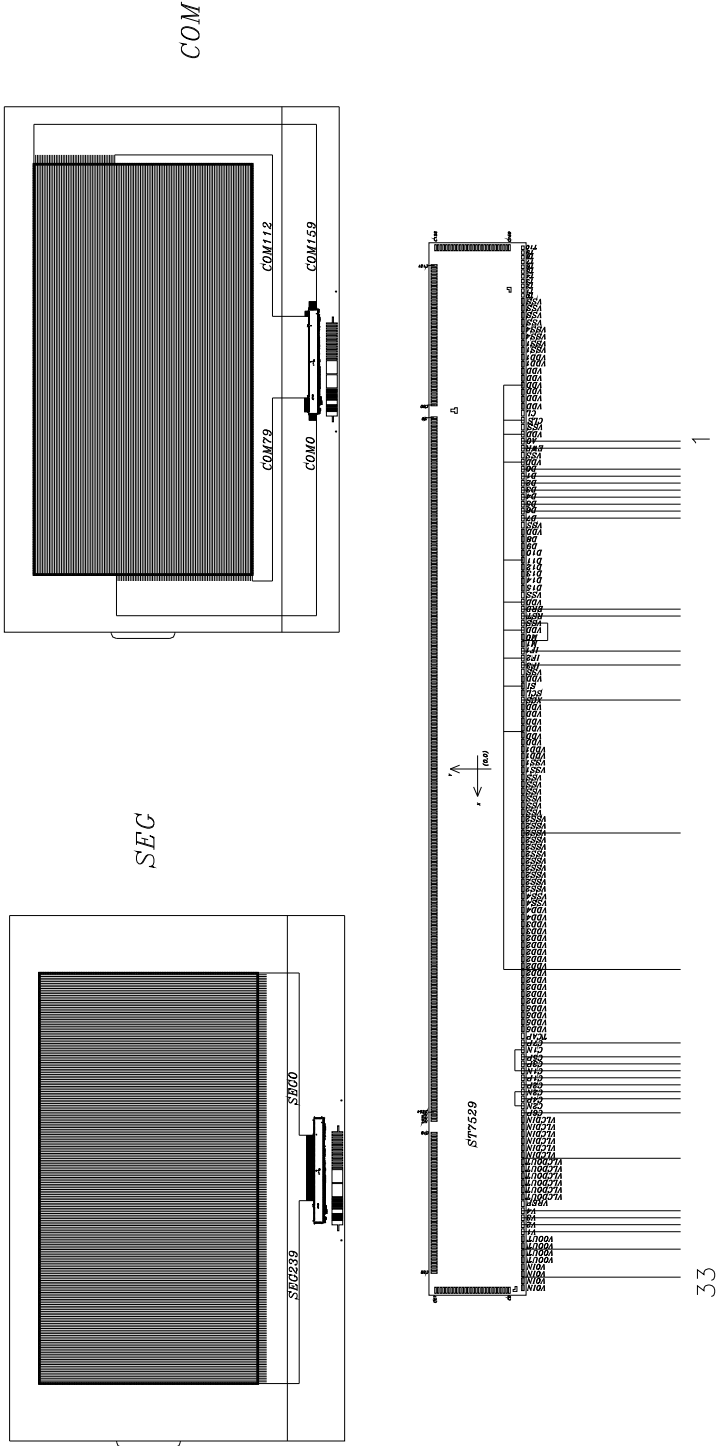

1	2	3	4	5	6	7	8	9	10	11	12	13	14	15	16
A0	EWB	D0	D1	D2	D3	D4	D5	D6	D7	ERD	RST	IF1	IF3	XCS	VSS
17	18	19	20	21	22	23	24	25	26	27	28	29	30	31	32
VDD	C7P	C5P	C3P	C1P	C1N	C2P	C2N	C4P	C6P	VLCD	V4	V3	V2	V1	V0OUT
															V0IN

6 RECOMMENDED CIRCUIT SCHEMATIC

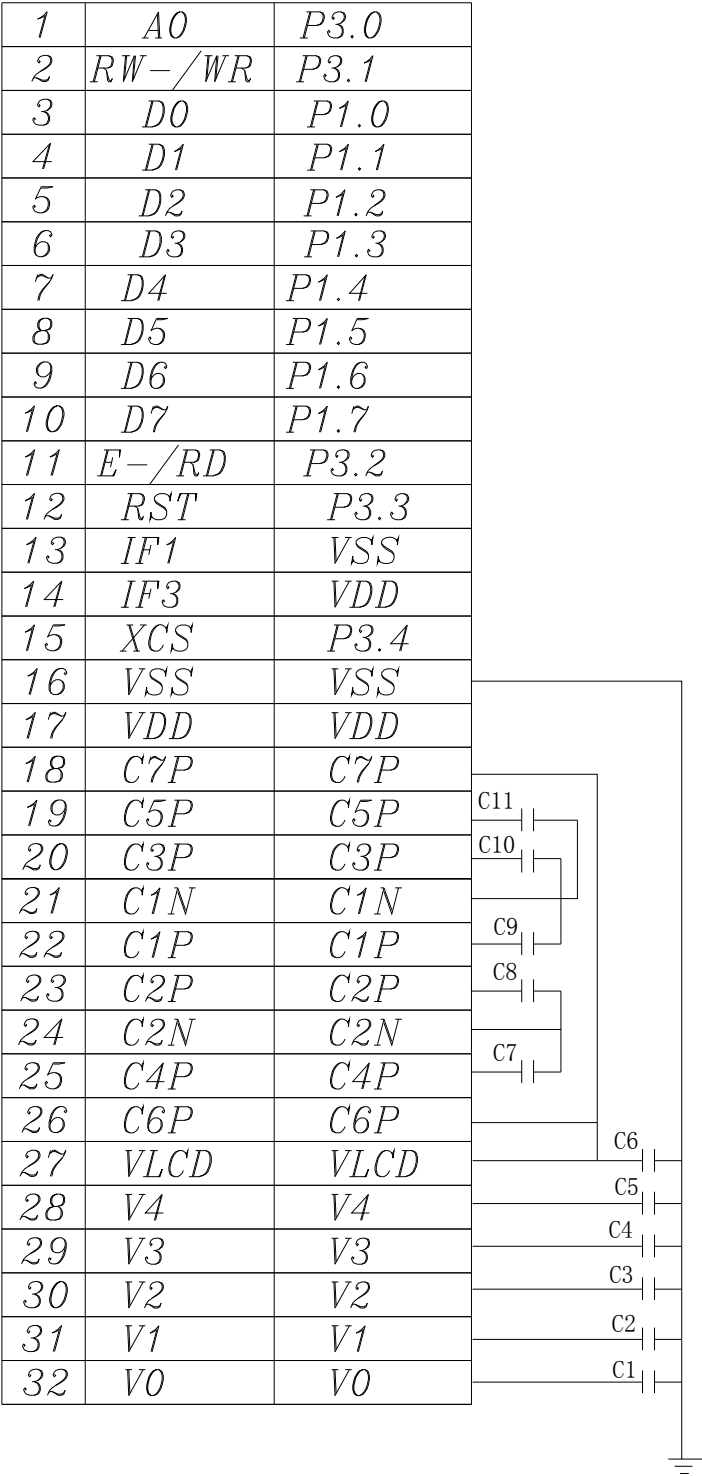

## 7 ELECTRO-OPTICAL CHARACTERISTICS

Item		Symbol	Min	Typ.	Max	Unit	Condition	
Supply Voltage (Logic)		V <sub>dd</sub> -V <sub>ss</sub>	2.7	3.0	3.3	V	-	
LCD current consumption		I <sub>dd</sub>	1.8		2.2	mA		
LCD Operating Voltage		V <sub>dd</sub> -V <sub>0</sub>	-	12.0	-	V	-20°C	
			11.4	11.6	11.8	V	25°C	
			-	11.1	-	V	80°C	
Response Time	FSTN Negative Type	T <sub>on</sub>	-	92	-	ms	-	
		T <sub>off</sub>	-	444	-			
	STN Negative Type	T <sub>on</sub>	-	116	-			
		T <sub>off</sub>	-	344	-			
	FSTN Positive Type	T <sub>on</sub>	-	112	-			
		T <sub>off</sub>	-	404	-			
Contrast Ratio		CR	2	3	-	-	-	
Viewing Angle	FSTN Negative Type	12H	θ1	-	54	-	Deg.	(CR≥2.0)
		6H	θ2	-	67	-		
		3H	θ3	-	50	-		
		9H	θ4	-	50	-		
	STN Negative Type	12H	θ1	-	52	-		
		6H	θ2	-	65	-		
		3H	θ3	-	50	-		
		9H	θ4	-	50	-		
	FSTN Positive Type	12H	θ1	-	55	-		
		6H	θ2	-	68	-		
		3H	θ3	-	50	-		
		9H	θ4	-	50	-		
LCD	FSTN Negative	V <sub>th</sub>	-	10.9	-	V	25°C	

Threshold Voltage	Type					
	STN Negative Type	Vth	-	11.0	-	
	FSTN Positive Type	Vth	-	10.8	-	

## 8 THE LED BACKLIGHT

### 8.1 MECHANICAL DRAWING FOR RGB BACKLIGHT

ROHS COMPLIANT

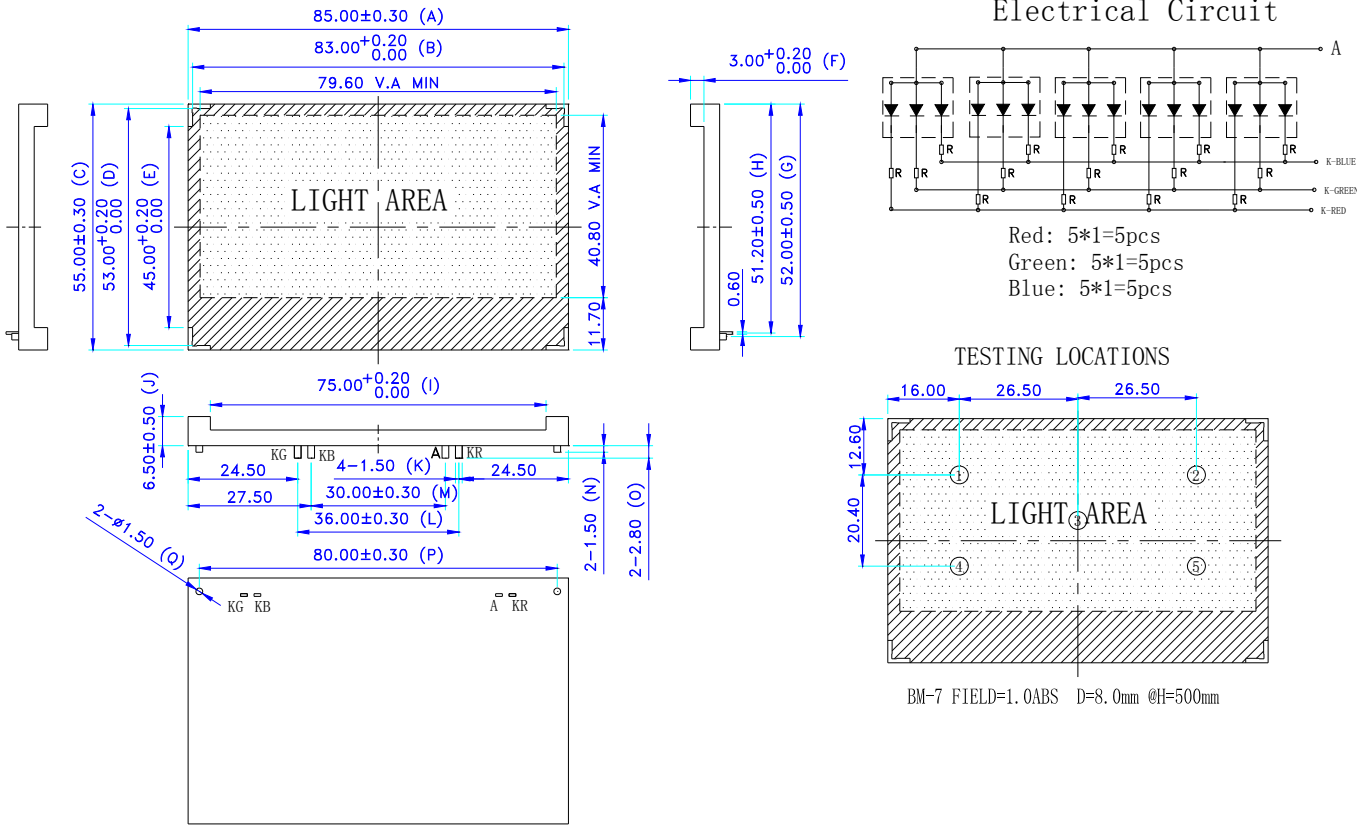

8.2 MECHANICAL DRAWING FOR ALL BACKLIGHT TYPE EXCEPT RGB

ROHS COMPLIANT

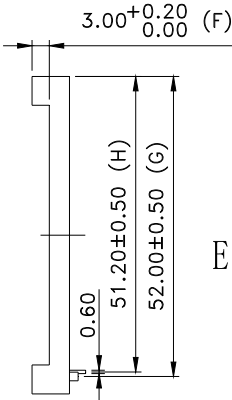
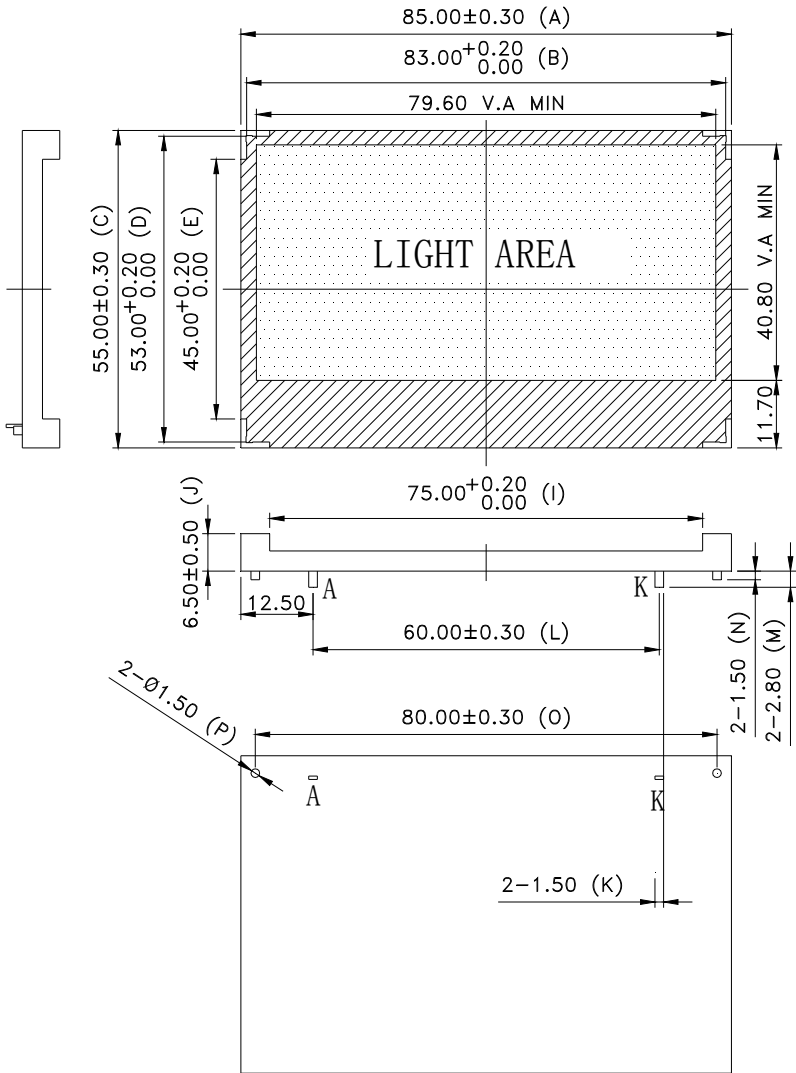

Electrical Circuit

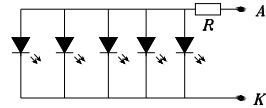

1\*5=5 pcs

TESTING LOCATIONS

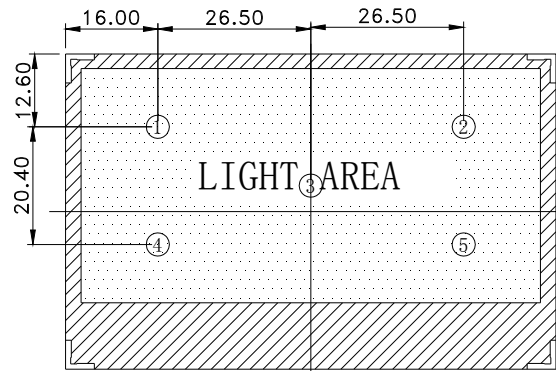

BM-7 FIELD=1.0ABS D=8.0mm @H=500mm

Note 1: LED Lifetime (Half Brightness) is estimated to be 30,000 hrs at 15 mA / LED (25°C).

Note 2: Please refer to the PWM white paper at [http://www.densitron.com/displays/led\\_support.aspx](http://www.densitron.com/displays/led_support.aspx) for background on extending LED backlight lifetimes.

Product No.	LMR5413	REV. H
-------------	---------	--------

Page	15 / 32
------	---------

### 8.3 BACKLIGHT ELECTRO-OPTICAL CHARACTERISTICS

#### 7.2.1 MIDNIGHT BLUE

-	SYMBOL	MIN.	TYP.	MAX.	UNIT	CONDITIONS
Input Voltage	$V_{IN}$	3.0	3.2	3.4	V	If = 75 mA
Forward Current	If	--	75	100	mA	--
Forward Dissipation	Pd	--	--	0.34	W	If = 75 mA
Reverse Voltage	$V_R$	--	--	5.0	V	--
Reverse Current	$I_R$	--	--	0.5	mA	$V_R = 5.0$ V
Luminous Intensity	$I_v$	20	--	--	Cd/m <sup>2</sup>	If = 75 mA
Luminous Uniformity	$\Delta I_v$	70	--	--	%	If = 75 mA
Emission Wavelength	p	465	--	475	--	If = 15 mA, Ta = 25°C Each chip

#### 7.2.2 JADE GREEN

-	SYMBOL	MIN.	TYP.	MAX.	UNIT	CONDITIONS
Input Voltage	$V_{IN}$	3.0	3.2	3.4	V	If = 50 mA
Forward Current	If	--	50	75	mA	--
Forward Dissipation	Pd	--	--	0.255	W	If = 50 mA
Reverse Voltage	$V_R$	--	--	5.0	V	--
Reverse Current	$I_R$	--	--	0.5	mA	$V_R = 5.0$ V
Luminous Intensity	$I_v$	15	--	--	Cd/m <sup>2</sup>	If = 50 mA
Luminous	$\Delta I_v$	70	--	--	%	If = 50 mA



Uniformity						
Emission Wavelength	p	569	--	575	--	If = 15 mA, Ta = 25°C Each chip

### 7.2.3 TANGERINE ORANGE

-	SYMBOL	MIN.	TYP.	MAX.	UNIT	CONDITIONS
Input Voltage	V <sub>IN</sub>	3.0	3.2	3.4	V	If = 50 mA
Forward Current	I <sub>f</sub>	--	50	75	mA	--
Forward Dissipation	P <sub>d</sub>	--	--	0.255	W	If = 50 mA
Reverse Voltage	V <sub>R</sub>	--	--	5.0	V	--
Reverse Current	I <sub>R</sub>	--	--	0.5	mA	V <sub>R</sub> = 5.0 V
Luminous Intensity	I <sub>v</sub>	60	--	--	Cd/m <sup>2</sup>	If = 50 mA
Luminous Uniformity	Δ I <sub>v</sub>	70	--	--	%	If = 50 mA
Emission Wavelength	p	600	--	610	--	If = 15 mA, Ta = 25°C Each chip

### 7.2.5 RGB TYPE

-	SYMBOL	COLORS	MIN.	TYP.	MAX.	UNIT	CONDITIONS
Input Voltage	V <sub>IN</sub>	RGB	3.0	3.2	3.4	V	If = 50 mA for Red and 75 mA for Blue & Green
Forward Current	I <sub>f</sub>	RED	--	50	75	mA	--
		BLUE	--	75	100	mA	
		GREEN	--	20	100	mA	
Power Dissipation	P <sub>d</sub>	RED	--	--	0.255	W	If = 50 mA
		BLUE	--	--	0.34	W	If = 75 mA
		GREEN	--	--	0.34	W	If = 75 mA
Reverse Voltage	V <sub>R</sub>	RGB	--	--	5.0	V	--
Reverse Current	I <sub>R</sub>	RGB	--	--	0.5	mA	V <sub>R</sub> = 5.0 V

# DENSITRON® DISPLAYS

Luminous Intensity	I <sub>v</sub>	RED	50	75	100	Cd/m <sup>2</sup>	If = 50 mA
		BLUE	80	--	--	Cd/m <sup>2</sup>	If = 75 mA
		GREEN	200	--	400	Cd/m <sup>2</sup>	If = 75 mA
Luminous Uniformity	Δ I <sub>v</sub>	RED	70	--	--	%	If = 50 mA
		BLUE	70	--	--	%	If = 75 mA
		GREEN	70	--	--	%	If = 75 mA
Emission Wavelength	p	RED	620	--	630	--	If = 10 mA, Ta = 25°C Each chip
		BLUE	465	--	476	--	If = 15 mA, Ta = 25°C Each chip
		GREEN	520	--	530	--	If = 15 mA, Ta = 25°C Each chip

**Note:**

## Red+Green

	SYMBOL	MIN.	TYP.	MAX.	UNIT	CONDITIONS
Luminous Intensity	I <sub>v</sub>	280	430	560	cd/m <sup>2</sup>	V <sub>f</sub> =3.2V
Emission Wavelength	λ <sub>p</sub>	553	—	570	nm	If=10mA Ta=25° C Each chip

## 7.2.4 SUNBURST YELLOW AND ARCTIC WHITE

-	SYMBOL	MIN.	TYP.	MAX.	UNIT	CONDITIONS
Input Voltage	V <sub>IN</sub>	3.0	3.2	3.4	V	If = 75 mA
Forward Current	I <sub>f</sub>	--	75	100	mA	--
Forward Dissipation	P <sub>d</sub>	--	--	0.34	W	If = 75 mA
Reverse Voltage	V <sub>R</sub>	--	--	5.0	V	--
Reverse Current	I <sub>R</sub>	--	--	0.5	mA	V <sub>R</sub> = 5.0 V
Luminous Intensity	I <sub>v</sub>	500	--	--	Cd/m <sup>2</sup>	If = 75 mA
Luminous Uniformity	Δ I <sub>v</sub>	70	--	--	%	If = 75 mA
Color Chromaticity	X	0.27	--	0.33	--	If = 15 mA, Ta = 25°C Each chip
	Y	0.27	--	0.33	--	

Product No.	LMR5413	REV. H
-------------	---------	--------

Page	18 / 32
------	---------

## 9 RELIABILITY TEST

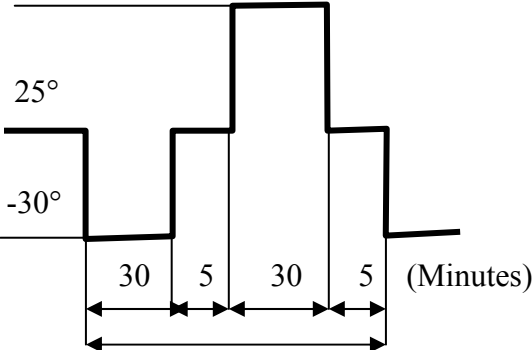
Items	Test Condition	Equipment	Test Result
High TEMP Storage	TEMP:80±2°C Time: 96h Restore:24h	Tenny	Passed
Low TEMP Storage	TEMP: -30±3 °C Time: 96h Restore:24h	Tenny	Passed
High TEMP Operating	TEMP: 80±2 °C Vop: 3.3V Time: 24h Restore:24h	Tenny	Passed
Low TEMP Operating	TEMP: -20±2 °C Vop: 3.3V Time: 24h Restore:24h	Tenny	Passed
High TEMP High Hum Storage	TEMP:40±2 °C Hum: 95%Rh Time: 96h Restore:24h	Tenny	Passed
Thermal Shock	TEMP:(°C) 80°C  25° -30° 30 5 30 5 (Minutes) 5 Cycles Restore:24h	Tenny	Passed

**10 THE LCD MEASURING METHOD AND EQUIPMENT**

- 1. Threshold Voltage and Response Time Measuring:
  - (1) Equipment

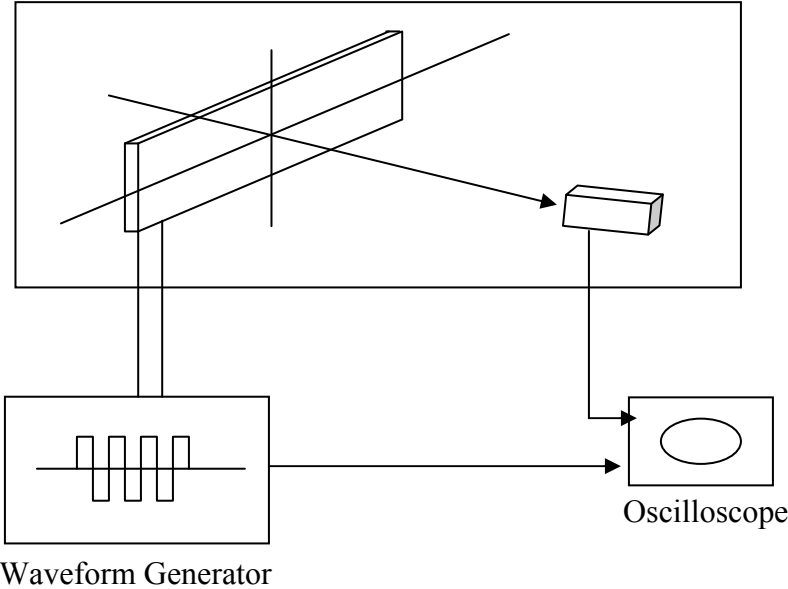

- (2) Definition
  - A. Threshold Voltage ( $V_{th}$ ):

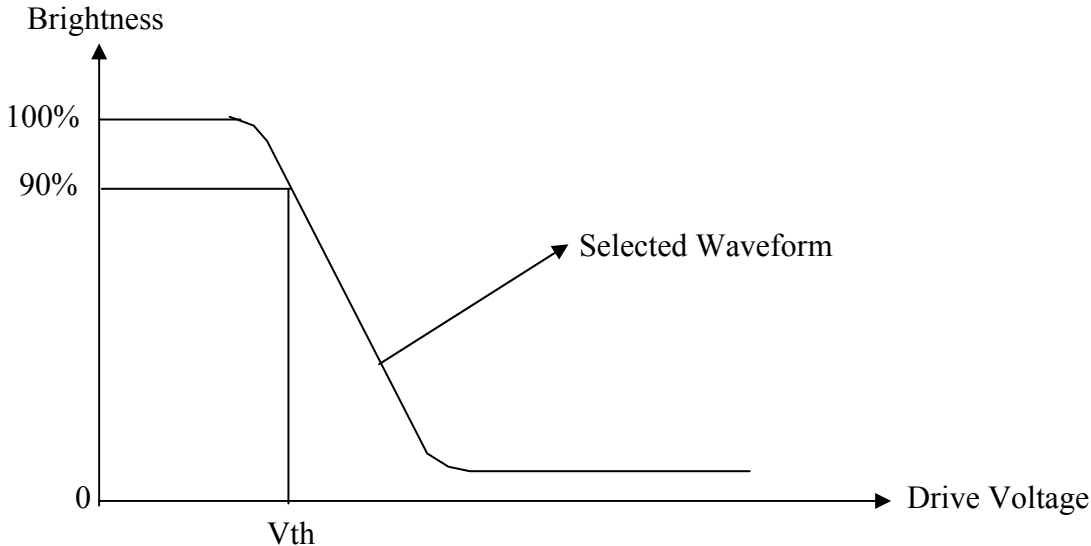

B. Response Time:

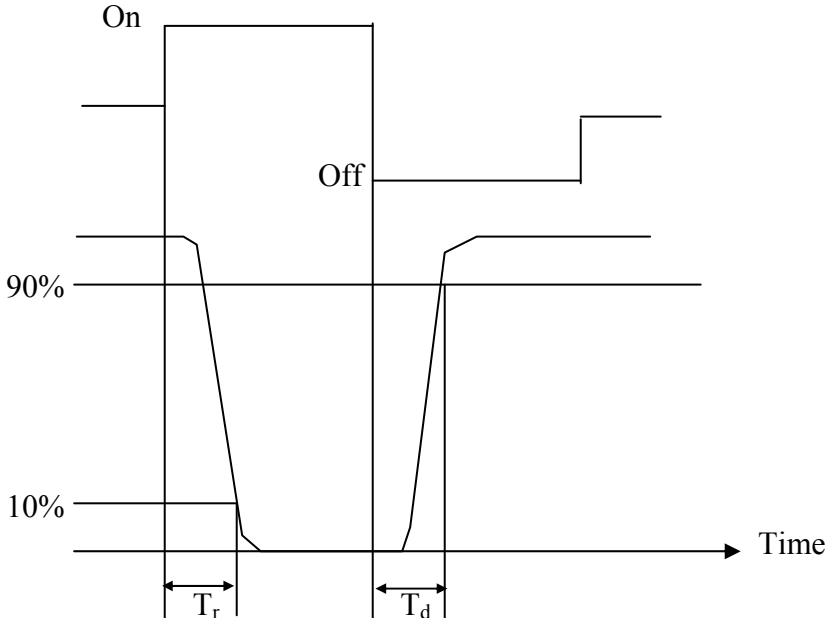

1. Contrast Measuring  
(1) Equipment

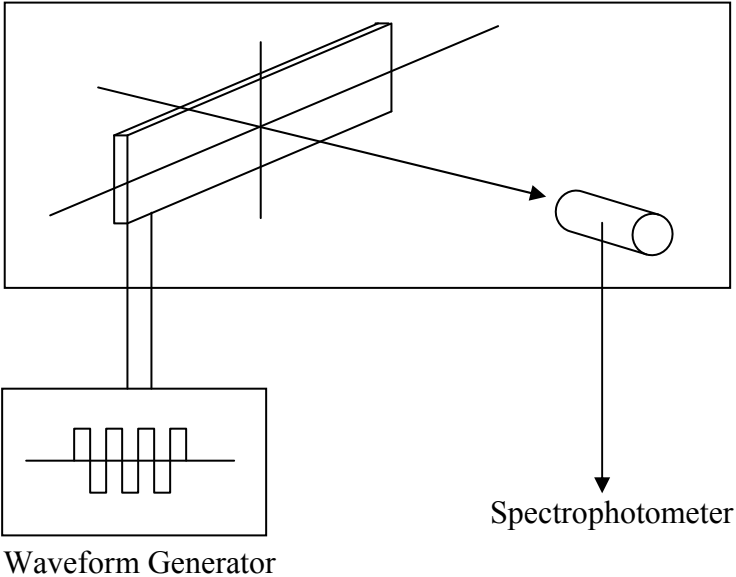

(2) Definition

A. Viewing angle:

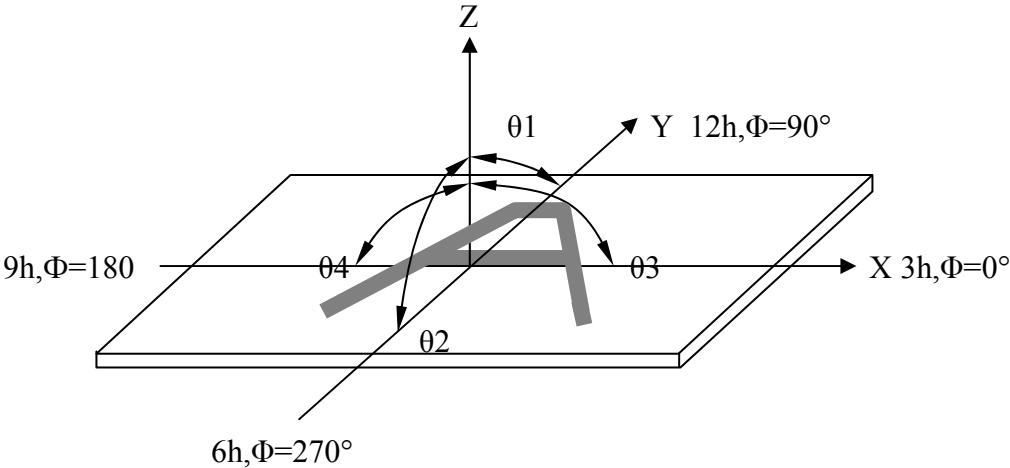

B. Contrast Ratio (Positive)

$$CR = \frac{\text{Brightness of non-selected wave-form}}{\text{Brightness of selected wave-form}}$$

## 11 INITIALIZING AND PROGRAMMING

```

/*
void lcd_full(unsigned char da1)
{
    unsigned char i,j;
    for (i=0;i<128;i++)
        for (j=0;j<240;j++)
            write_dat(da1);
}
void lcd_line1(void)
{
    unsigned char i,j;
    for (i=0;i<32;i++)
    {
        for (j=0;j<240;j++)        write_dat(0x00);
        for (j=0;j<240;j++)        write_dat(0x1f);
        for (j=0;j<240;j++)        write_dat(0x1f);
        for (j=0;j<240;j++)        write_dat(0x1f);
    }
}
void lcd_line2(void)
{
    unsigned char i,j;
    for (i=0;i<32;i++)
    {
        for (j=0;j<240;j++)        write_dat(0x1f);
        for (j=0;j<240;j++)        write_dat(0x00);
        for (j=0;j<240;j++)        write_dat(0x1f);
        for (j=0;j<240;j++)        write_dat(0x1f);
    }
}
void lcd_line3(void)
{
    unsigned char i,j;
    for (i=0;i<32;i++)
    {
        for (j=0;j<240;j++)        write_dat(0x1f);
        for (j=0;j<240;j++)        write_dat(0x1f);
        for (j=0;j<240;j++)        write_dat(0x00);
        for (j=0;j<240;j++)        write_dat(0x1f);
    }
}
void lcd_line4(void)
{
    unsigned char i,j;
    for (i=0;i<32;i++)
    {
        for (j=0;j<240;j++)        write_dat(0x1f);
        for (j=0;j<240;j++)        write_dat(0x1f);
        for (j=0;j<240;j++)        write_dat(0x1f);
        for (j=0;j<240;j++)        write_dat(0x00);
    }
}
void lcd_erec1(void)
{
    unsigned char i,j;
    for (i=0;i<128;i++)
        for (j=0;j<60;j++)
            write_dat(0x00);
}

```

```

        write_dat(0x1f);
        write_dat(0x1f);
        write_dat(0xff);
    }
}
void lcd_erec2(void)
{
    unsigned char i,j;
    for (i=0;i<128;i++)
        for (j=0;j<240/4;j++)
        {
            write_dat(0x1f);
            write_dat(0x00);
            write_dat(0x1f);
            write_dat(0x1f);
        }
}
void lcd_erec3(void)
{
    unsigned char i,j;
    for (i=0;i<128;i++)
        for (j=0;j<240/4;j++)
        {
            write_dat(0x1f);
            write_dat(0x1f);
            write_dat(0x00);
            write_dat(0x1f);
        }
}
void lcd_erec4(void)
{
    unsigned char i,j;
    for (i=0;i<128;i++)
        for (j=0;j<240/4;j++)
        {
            write_dat(0x1f);
            write_dat(0x1f);
            write_dat(0x1f);
            write_dat(0x00);
        }
}
*/
void ReadEEPROM(void)
{
    write_com(0x30); // Ext = 0
    write_com(0x07); // Initial code (1)
    write_dat(0x19);
    write_com(0x31); // Ext = 1
    write_com(0xcd); // EEPROM ON
    write_dat(0x00); // Entry "Read Mode"
    delay_ms(100); // Waite for EEPROM Operation ( 100ms )
    write_com(0xfd); // Start EEPROM Reading Operation
    delay_ms(100); // Waite for EEPROM Operation ( 100ms )
    write_com(0xcc); // Exist EEPORM Mode
    write_com(0x30); // Ext = 0
}
void lcdreset(unsigned char VOL)//
{
    unsigned char i;
    res=0;
    delay_ss(1);
}

```



```

res=1;
cs=0;
write_com(0x30); // ext=0
write_com(0x94); // sleep out
write_com(0xd1); // osc on
write_com(0x20); // power control set
write_dat(0x08); // booster must be on first
delay_ms(2);
write_com(0x20); // power control set
write_dat(0x0b); // booster,regulator follower on
write_com(0x81); // electronic control
write_dat(VOL); // set vop low: 00~3f      0x35,0x03=13.55
write_dat(0x03); // hige:00~07      0x1e,0x03=12.5
write_com(0xca); // display control
write_dat(0x04); //
write_dat(0x1f); // 1f duty=1/128
write_dat(0x00); //
write_com(0xa6); // normal display
write_com(0xbb); // com scan direction
write_dat(0x01); // 0~79,159~80
write_com(0xbc); // data scan direction
write_dat(0x02); //

write_dat(0x01); //
write_dat(0x02); //
write_com(0x75); // line address set
write_dat(0x00); // start line =0
write_dat(0x7f); // end line =127
write_com(0x15); // column address set
write_dat(0x05); // start column =0
write_dat(0x54); // end column =79

write_com(0x31); // ext=1
write_com(0x32); // analog circuit set
write_dat(0x00); // osc frequency=000 (default)
write_dat(0x00); // booster efficiency=01 (default)
write_dat(0x02); // 1/12=0x02 lease
write_com(0x34); // dithering off
ReadEEPROM(); // read eeprom flow
write_com(0xaf); // display on
write_com(0x5c); // write data pointer

write_com(0x31); // ext=1
write_com(0x34); // dithering off
write_com(0x20); // set gray level,32 level
for(i=0;i<33;i=i+2) write_dat(i);
write_com(0x21);
for(i=0;i<33;i=i+2) write_dat(i);
ReadEEPROM(); // read eeprom flow
write_com(0x30); // ext=1
write_com(0xaf); // display on
write_com(0x5c); // write data
}
void lcd_image(unsigned char code *p)
{
    unsigned char i,j,k,l;
    int a;
    write_com(0x30); // ext=0
    write_com(0x75); // line address set
    write_dat(80); // start line =80
    write_dat(127); // end line =127

```

Product No.	LMR5413	REV. H
-------------	---------	--------

Page	25 / 32
------	---------

```

write_com(0x5c); // write data
for (i=0;i<48;i++)
{
    for(j=0;j<240/8;j++)
    {
        l=*p;
        for(k=0;k<8;k++)
        {
            if((l&0x80)==0)        write_dat(0xff);
            else                    write_dat(0x00);

            l=l<<1;
        }
        p++;
    }
}
a=p;
write_com(0x30); // ext=0
write_com(0x75); // line address set
write_dat(0);          // start line =0
write_dat(79);         // end line =127
write_com(0x5c); // write data
for (i=0;i<80;i++)
{
//    p=a+2400-(i+1)*30;
    for (j=0;j<240/8;j++)
    {
        l=*p;
        for(k=0;k<8;k++)
        {
            if((l&0x80)==0)        write_dat(0xff);
            else                    write_dat(0x00);

            l=l<<1;
        }
        p++;
    }
}
}
void lcd_gray_image(unsigned char code *p)
{
    unsigned char i,j,k,l,m;
    write_com(0x30); // ext=0
    write_com(0x75); // line address set
    write_dat(80); // start line =80
    write_dat(127); // end line =127
    write_com(0x5c); // write data
    for (i=0;i<48;i++)
    {
        for(j=0;j<60;j++)
        {
            l=*p;
            for(k=0;k<4;k++)
            {
                m=(l&0xD0)>>6;
                switch(m)
                {
                    case 0: write_dat(0xff);break;
                    case 1: write_dat(0x81);break;
                    case 2: write_dat(0x41);break;
                    case 3: write_dat(0x00);break;
                }
                l=l<<2;
            }
        }
    }
}

```

```

        p++;
    }
}
write_com(0x30); // ext=0
write_com(0x75); // line address set
write_dat(0);      // start line =0
write_dat(79);    // end line =79
write_com(0x5c); // write data
for (i=0;i<80;i++)
{
    for(j=0;j<60;j++)
    {
        l=*p;
        for(k=0;k<4;k++)
        {
            m=(l&0xD0)>>6;
            switch(m)
            {
                case 0: write_dat(0xff);break;
                case 1: write_dat(0x81);break;
                case 2: write_dat(0x41);break;
                case 3: write_dat(0x00);break;
            }
            l=l<<2;
        }
        p++;
    }
}
}
void testlcd(unsigned char i)
{
    switch(i)
    {
        case 0: lcd_image(image_yes1);
                break;
        case 1: lcd_image(image_yes2);
                break;
        case 2: lcd_gray_image(image_yes3);
                break;
        case 3: lcd_gray_image(image_yes4);
                break;
        case 4: lcd_image(image_yes5);
                break;
        case 5: lcd_image(image_yes6);
                break;
        case 6: lcd_image(image_yes7);
                break;
        case 7: lcd_image(image_yes8);
                break;
    }
}
}

```

NOTE: Please make sure to follow the Read EEPROM procedure for the optimal contrast setting.

```
void ReadEEPROM( void )
{
    Write( COMMAND, 0x0030 );           // Ext = 0
    Write( COMMAND, 0x0007 );           // Initial code (1)
    Write( DATA, 0x0019 );
    Write( COMMAND, 0x0031 );           // Ext = 1
    Write( COMMAND, 0x00CD );           // EEPROM ON
    Write( DATA, 0x0000 );             // Entry "Read Mode"
    Delay( 100ms );                     // Waite for EEPROM Operation ( 100ms )
    Write( COMMAND, 0x00FD );           // Start EEPROM Reading Operation
    Delay( 100ms );                     // Waite for EEPROM Operation ( 100ms )
    Write( COMMAND, 0x00CC );           // Exist EEPROM Mode
    Write( COMMAND, 0x0030 );           // Ext = 0
}
}
```

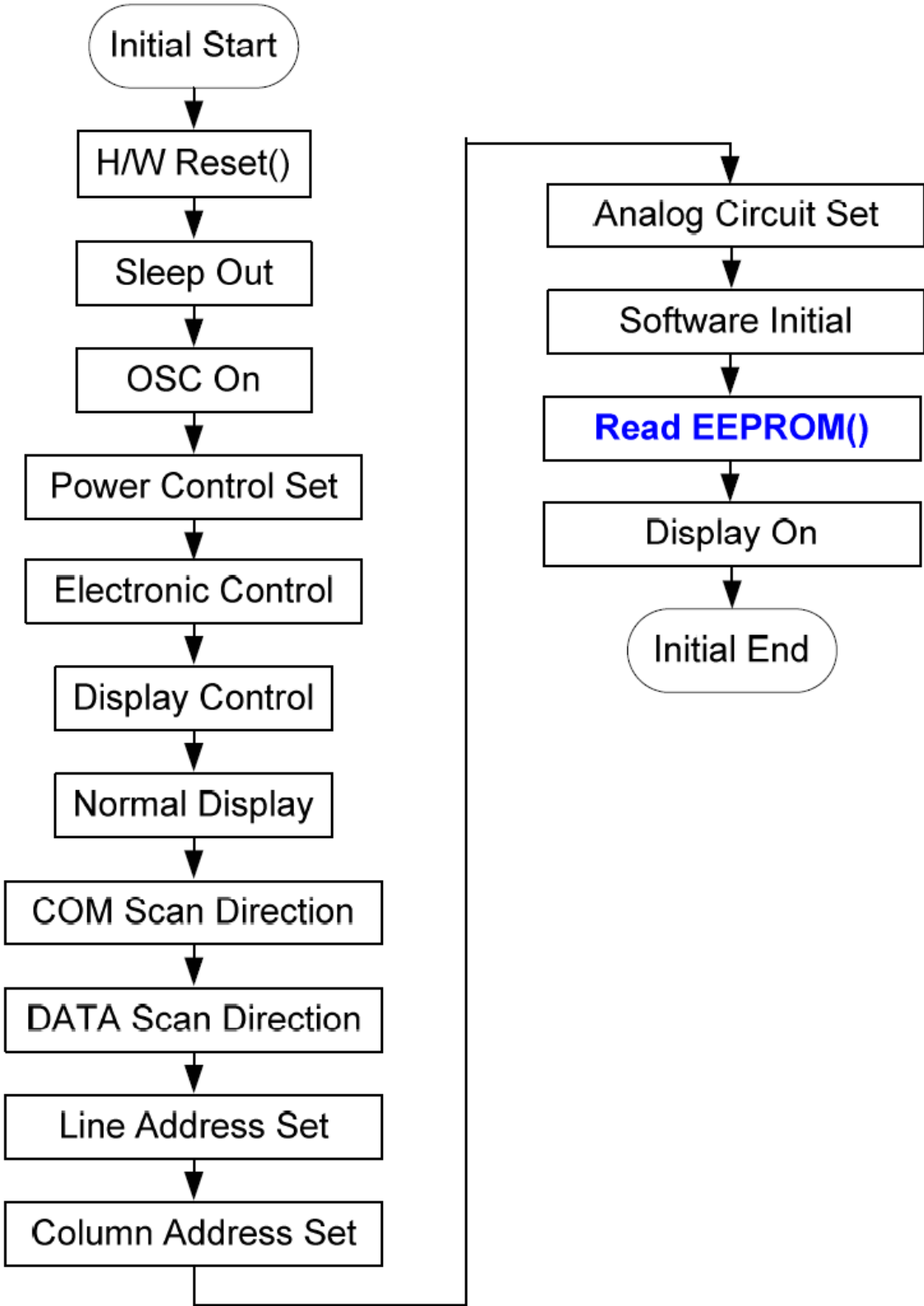

## 12 PART NUMBER DESCRIPTION FOR AVAILABLE OPTIONS

### LMR5413①②240G128③④⑤

①

**Polarizer Type**

E = Transmissive Negative Mode

B = Transflective Positive Mode

②

**Backlight Color**

G = Jade Green

B = Midnight Blue

W = Arctic White

O = Tangerine Orange

Y = Sunburst Yellow

T = RGB TYPE

③

**Fluid Type and Temperature Range**

W = Wide temp. range

④

**Fluid Type and Temperature Compensation**

N = STN

F = FSTN

⑤

**Background Color**

B = Blue mode STN (Ocean Blue)

### 13 STANDARD SPECIFICATIONS FOR PRODUCT QUALITY

1. Manner of Test:
  - 1.1- The Test must be under 40w Fluorescent Light and The Distance of View Must Be At 30cm.
  - 1.2- The Test Direction Is Based On Around 15°- 45° of Vertical Line.
2. Definition of Defects:
  - 2.1- Major Defects  
Non-Display, Segment Missing, Over Current, Segment Short, Sealant Softens, Wrong Polarizer Direction
  - 2.2- Minor Defects: The Others.
3. Major Defects Should Be In AQL 0.25, and The Minor In AQL 1.00.
4. Inspection Item and Standards

Item	The standard of quality inspection	Checking Manner	Quality Ratio
Frame	Smooth and even surface, no crack, no scratch, no rust, and not be bent out of shape. The range between convex and concave is: $d \leq 0.35\text{mm}$ and the frame must be connected to the ground.	Checking With Eyes And Using Vernier Caliper, Multimeter	100%
LCD	1. The major defects would be rejected. 2. No scratch and no dust on the LCD glass surface. 3. $D \leq 0.15\text{mm}$ $n \leq 2$ diameter of bubble: $d \leq 0.5$ $n \leq 2$ damaged size of polarizer: $d \leq 0.15\text{mm}$ , $n \leq 2$ . 4. No scratch and dust between the LCD and LED.	Check It When Displaying	100%
The Relative Position of LCD and Frame	1. The LCD should not be twisted. 2. The LCD graphic should be in the middle position of the frame.	Checking With Eyes	100%
The Relative Position of PCB Panel and Frame	1. The frame installing direction must be correct. 2. The twisted angle of the pin is from 45° to 60°. 3. The pin is vertical to PCB panel and it should be in the middle position of the installing holes.	Checking With Eyes	100%
LED	1. The led would be yellow-green. 2. The led would be uniform.	Checking With Eyes	100%
Function Test	1. The major defects must be reject. 2. Test flow chart (see attached chart) 3. Background changes evenly and no disorderly displaying phenomenon. 4. Display no shortage.	Check It When Displaying	100%

Note: D = Diameter, N = Quantity, Unit = mm

## 14 HANDLING PRECAUTIONS

### *Safety*

If the LCD panel breaks, be careful not to get the liquid crystal fluid in your mouth or in your eyes.  
If the liquid crystal touches your skin or clothes, wash it off immediately using soap and plenty of water.

### *Mounting and Design*

Place a transparent plate (e.g. acrylic, polycarbonate or glass) on the display surface to protect the display from external pressure. Leave a small gap between the transparent plate and the display surface.  
When assembling with a zebra connector, clean the surface of the pads with alcohol and keep the surrounding air very clean. Design the system so that no input signal is given unless the power supply voltage is applied.

### *Caution during LCD cleaning*

Lightly wipe the display surface with a soft cloth soaked with Isopropyl alcohol, Ethyl alcohol or Trichlorotrifluoroethane. Do not wipe the display surface with dry or hard materials that will damage the polariser surface. Do not use aromatic solvents (toluene and xylene), or ketonic solvents (ketone and acetone).

### *Caution against static charge*

As the display uses C-MOS LSI drivers, connect any unused input terminal to VDD or VSS. Do not input any signals before power is turned on. Also, ground your body, work/assembly table and assembly equipment to protect against static electricity.

### *Packaging*

Displays use LCD elements, and must be treated as such. Avoid strong shock and drop from a height.  
To prevent displays from degradation, do not operate or store them exposed directly to sunshine or high temperature/humidity.

### *Caution during operation*

It is indispensable to drive the display within the specified voltage limit since excessive voltage shortens its life. Direct current causes an electrochemical reaction with remarkable deterioration of the display quality. Give careful consideration to prevent direct current during ON/OFF timing and during operation.  
Response time is extremely delayed at temperatures lower than the operating temperature range while, at high temperatures, displays become dark. However, this phenomenon is reversible and does not mean a malfunction or a display that has been permanently damaged. If the display area is pushed on hard during operation, some graphics will be abnormally displayed but returns to a normal condition after turning off the display once. Even a small amount of condensation on the contact pads (terminals) can cause an electrochemical reaction which causes missing rows and columns. Give careful attention to avoid condensation.

### *Storage*

Store the display in a dark place where the temperature is 25°C ± 10°C and the humidity below 50%RH.  
Store the display in a clean environment, free from dust, organic solvents and corrosive gases.  
Do not crash, shake or jolt the display (including accessories).

Product No.	LMR5413	REV. H
-------------	---------	--------

Page	32 / 32
------	---------